

STATEMENT OF SUBDIVISION  
EDEN VALLEY PROJECT  
Sweetwater County, Wyoming

The subdivision of the Eden Valley Project as it appears on the plat is made with the free consent and in accordance with the desire of the United States of America as owner and proprietor thereof, pursuant to the provisions of the Acts of Congress of May 10, 1939 (53 Stat. 685, 719), of June 28, 1949 (63 Stat. 277), and of May 28, 1954 (68 Stat. 155), under delegation of authority contained in Title 7, Code of Federal Regulations, Section 600.6, as revised November 17, 1955 (20 F.R. 8517). The strips of land shown as roads upon lands owned by the United States of America are to be made the subject of a grant of easement for road purposes by separate instruments to be duly recorded.

UNITED STATES OF AMERICA  
By Richard H. Hopkins  
State Conservationist  
Soil Conservation Service  
United States Department of Agriculture

ACKNOWLEDGMENT  
STATE OF WYOMING )  
COUNTY OF Natrona ) ss.  
On this 9th day of June, 1958, before me the undersigned, a Notary Public in and for the County and State aforesaid, personally appeared R. H. Hopkins, State Conservationist, Soil Conservation Service, United States Department of Agriculture, who is personally known to me and personally known to me to be such State Conservationist and the same person who executed the within and foregoing instrument and he duly acknowledged the execution of the same for and on behalf of the United States of America.  
In witness whereof, I have hereunto set my hand and affixed my official seal the day and year last above written.

Charles E. Bayless  
Notary Public

My commission expires:  
6-6-61

SURVEYOR'S CERTIFICATE

I hereby certify that the survey of the exterior boundaries and rights of way and the attached plat of Farm Unit E-1, Eden Valley Irrigation Project, Sweetwater County, Wyoming, were made on the ground, under my supervision; that the survey of the exterior boundaries and rights of way is accurately represented upon the plat to which this certificate is affixed, and that said plat shows the exterior boundaries of the unit of land embraced therein by true courses and distances, all of which have been tied in with the section or quarter section corners established by the official United States Government survey thereof.

Signed this 27 day of August, 1958.  
William E. Lehman  
Project Engineer

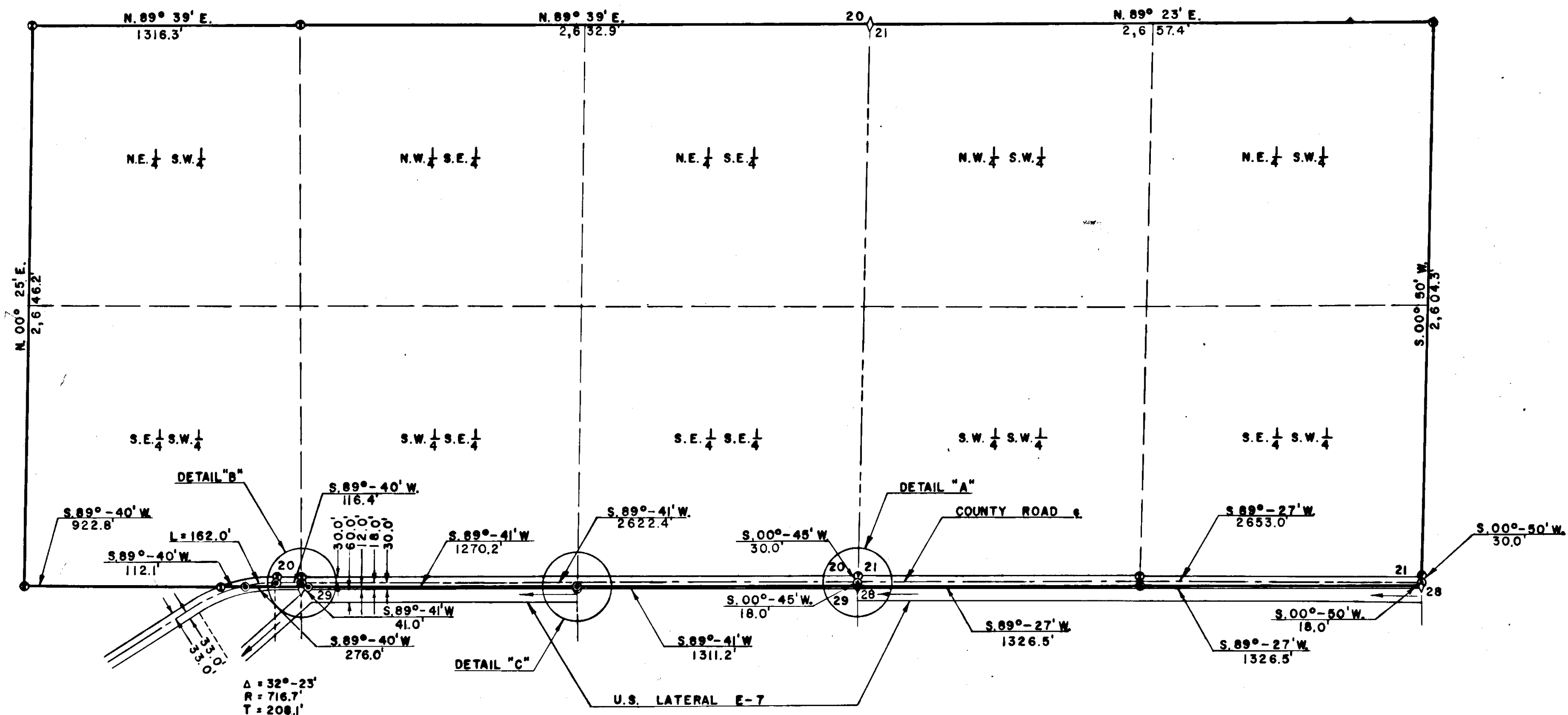
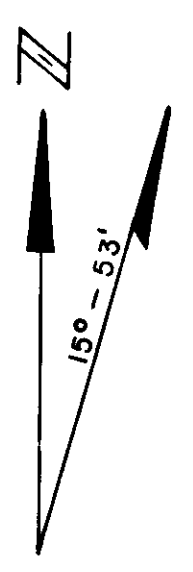

Δ = 32°-23'  
R = 716.7'  
T = 208.1'  
L = 405.1'  
D = 8°-00'

ACREAGE TABLE

Total gross acreage	401.02
Irr. wks. acreage	---
Road right of way acreage	6.13
Usable acreage	394.89
Class 1	---
Class 2	---
Class 3	190.4
Class 4	23.9
Class 6	180.6
Total Irrigable	214.3
Total non-irrigable	180.59

LEGEND

- Monument
- Iron pin or bridge spike
- Traverse point
- Ownership boundary

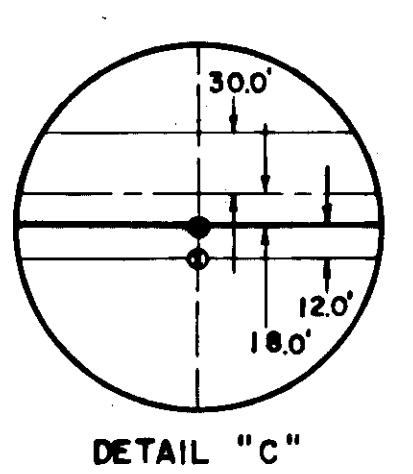
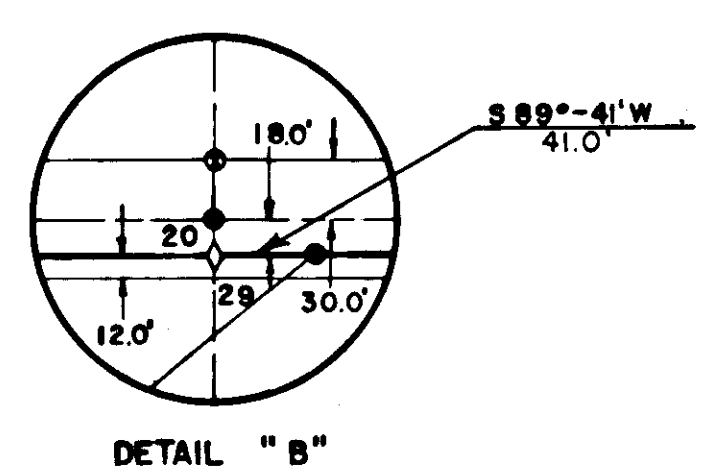
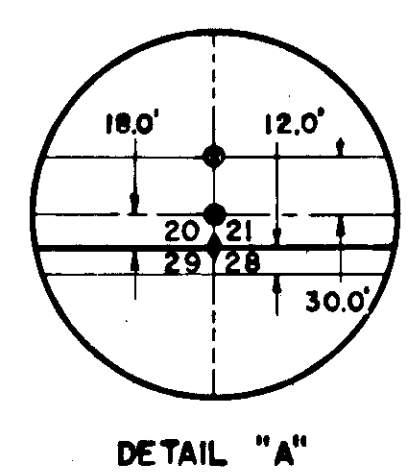
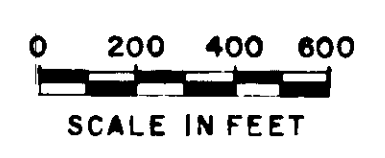

<b>PLAT</b>	
FARM UNIT E-1 EDEN VALLEY PROJECT Sec. 20 & 21, T25 N. R105 W. Sweetwater County, Wyoming	
<b>U. S. DEPARTMENT OF AGRICULTURE SOIL CONSERVATION SERVICE</b>	
Designed _____	Date _____
Drawn _____	Approved by <u>William E. Lehman</u>
Traced <u>J. E. B.</u>	Title <u>Acting Head - E&amp;M&amp;U</u>
Checked <u>R. H. D.</u>	Sheet _____
	Drawing No. _____
	No. 1 of 1
	5-15-57
	5, E-15, 057